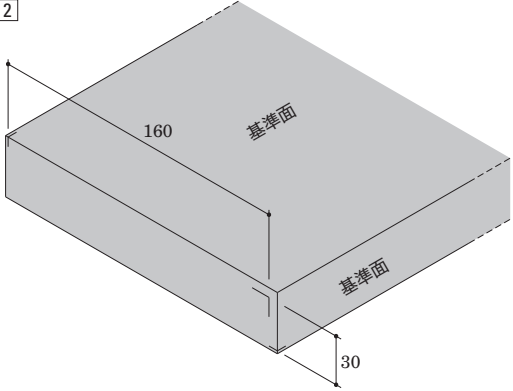
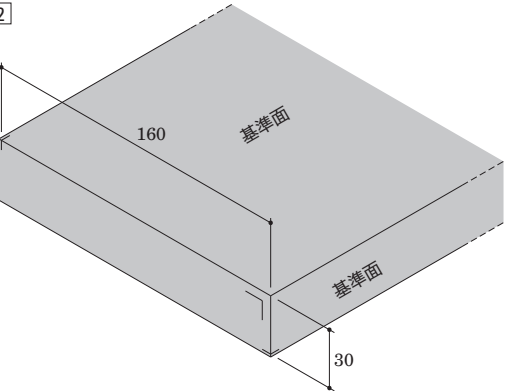
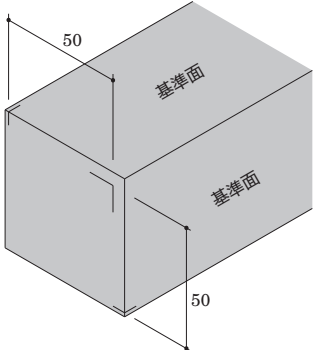
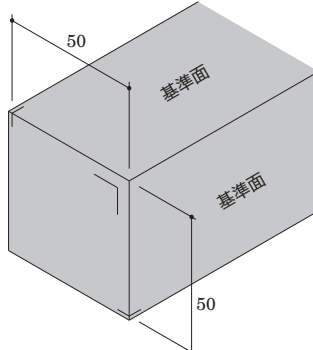
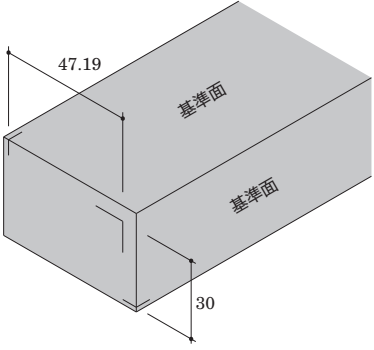
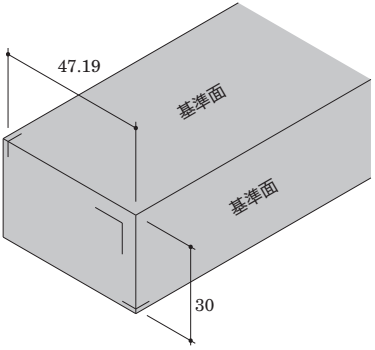
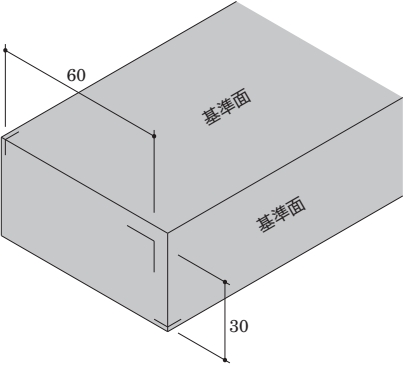
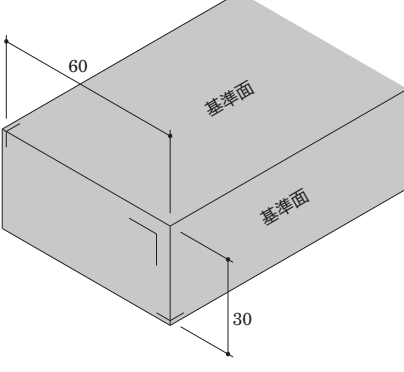
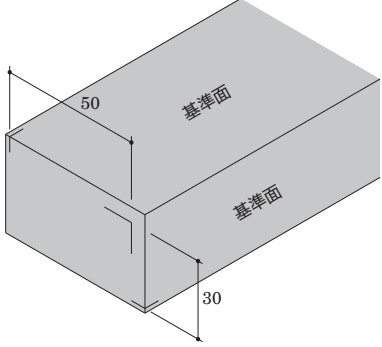
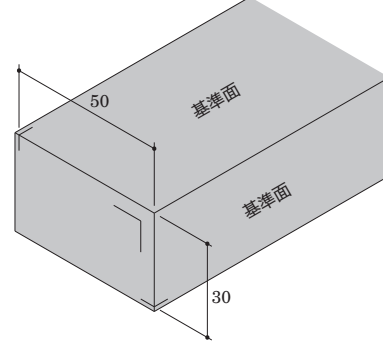
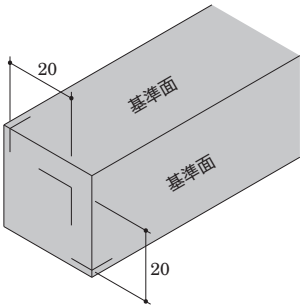

## 「第 3 章 2 級建築大工技能の実技」寸法引出し線につきまして

本書第 3 章の下記ページの寸法引出し線につきまして、下表右のように修正ください。

ページ	誤	正
222	<p data-bbox="326 454 350 484">②</p> 	<p data-bbox="906 454 930 484">②</p> 
224	<p data-bbox="326 886 378 916">① 1)</p> 	<p data-bbox="906 886 958 916">① 1)</p> 
229	<p data-bbox="326 1317 350 1347">①</p> 	<p data-bbox="906 1317 930 1347">①</p> 
232	<p data-bbox="326 1712 350 1742">①</p> 	<p data-bbox="906 1712 930 1742">①</p> 

ページ	誤	正
235	<p data-bbox="329 236 354 270">①</p> 	<p data-bbox="894 236 919 270">①</p> 
238	<p data-bbox="329 645 354 679">①</p> 	<p data-bbox="894 645 919 679">①</p> 